

ELEVATION A TO EAST

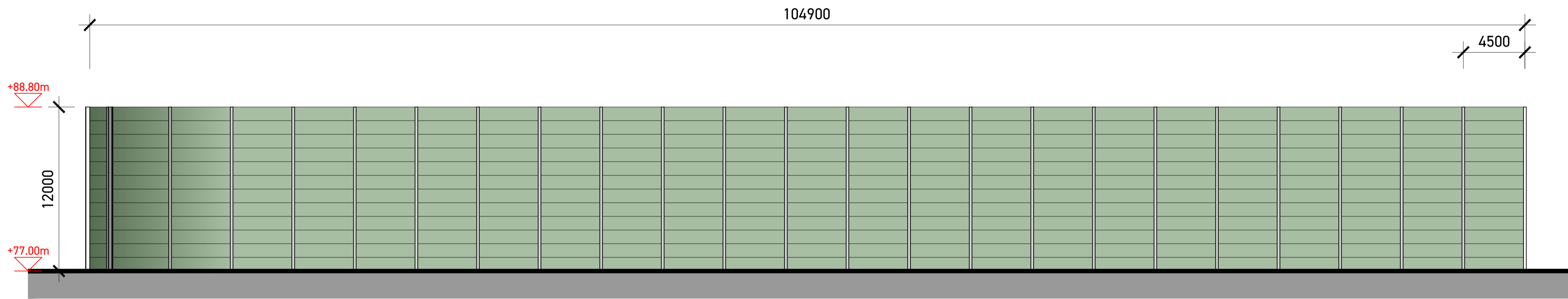

ELEVATION B TO NORTH

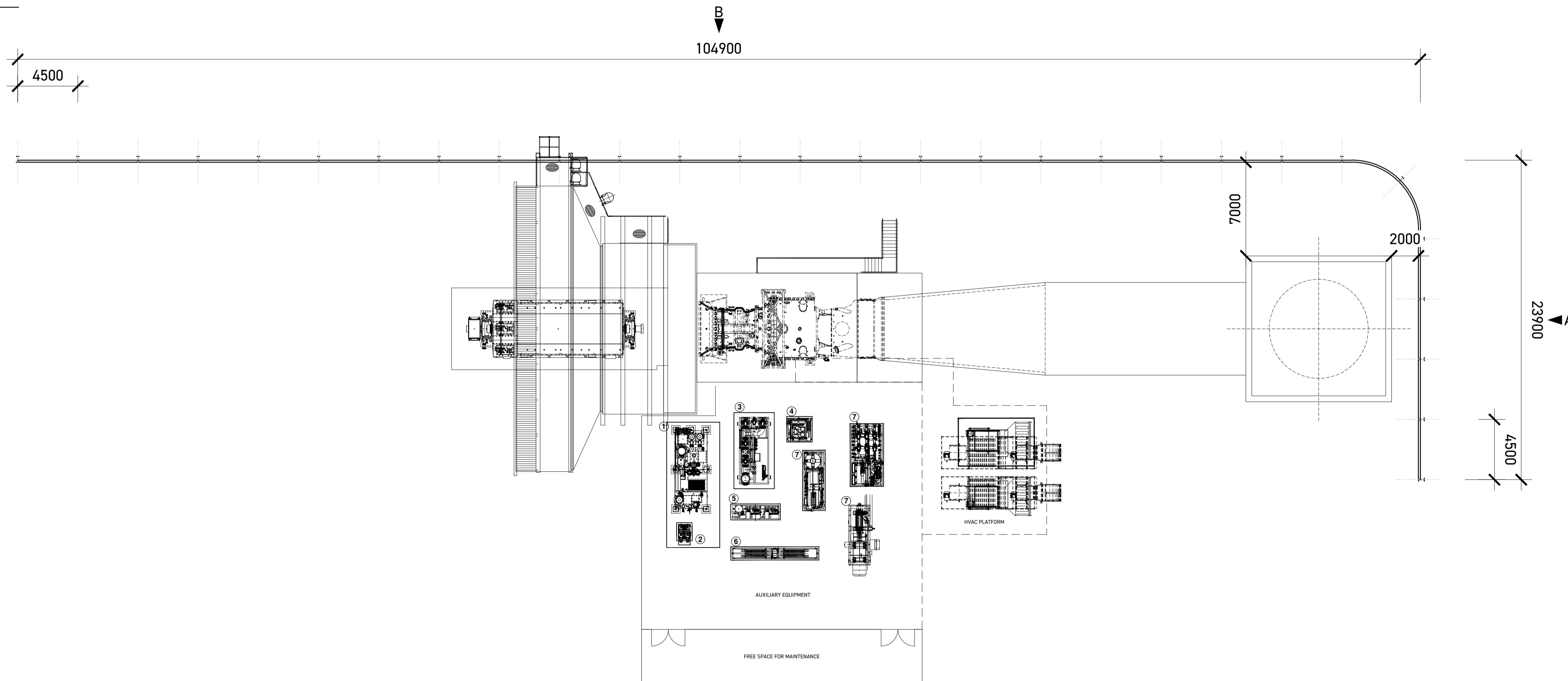

PLAN [1:200]

- NOTES -

150mm THICK ACOUSTIC PANELS FILLED WITH STRAND FIBREGLASS / MINERAL WOOL AND FITTED BETWEEN STRUCTURAL STEEL COLUMNS AT 4.5m CENTRES

Rev	Description	Date
PLANNING		
Client Kilshane Energy Ltd		
Project POWER STATION Kilshane, Dublin 11		
Date	December 2025	
Scale	1:200 @ A1	
Drawing ACOUSTIC WALL PLAN & ELEVATIONS		
Job Nr	Drawing Nr	Rev

165 PL.AW.01

